

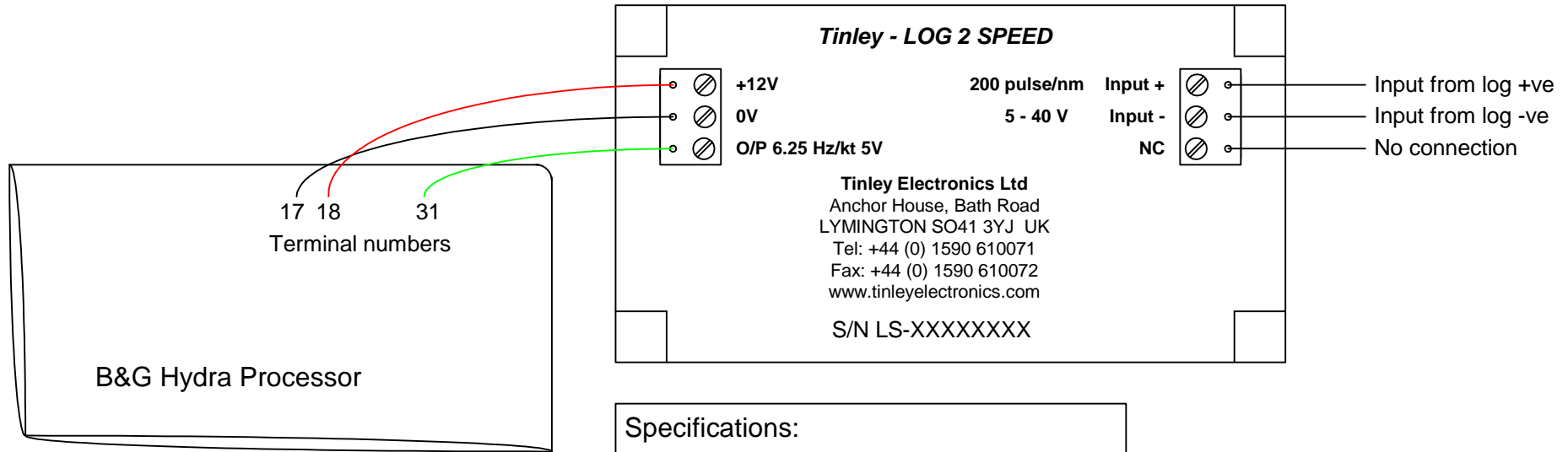

Tinley Electronics 'LOG 2 SPEED' Installation Diagram



Specifications:

Input Voltage 9-18 Volts
 Current 90 mA @ 12 Volts
 Input Opto-isolated 5-40 Volts
 Input current 4mA @ 5 V, 11mA @ 12V
 Output 5 V source 0.5mA, sink 50mA
 Tested Speed Range 0.5 to 50 knots
 Input 200 pulse/nm
 Output 5V 6.25 Hz/kt