



Product Identification Guide

**Rev. 2.10
August, 2011**

Premier Way, Abbey Park
Romsey, Hampshire, S051 9DH
England

Tel: +44 (0) 1590 689699
Fax: +44 (0) 1590 610072
www.bandgservice.co.uk

© B&G Ltd. 2002 - 2011
The copyright of this Manual is the property of Brookes & Gatehouse Ltd.

CONTENTS

Description	Page
BOAT SPEED SENSORS	2
IMPELLER TYPE	2
PADDLEWHEEL TYPE.....	3
PADDLEWHEEL SPARES KITS.....	7
SONIC SPEED	8
XTL- MICROSONIC SPEED SENSOR.....	8
ULTRASONIC SPEED	9
DEPTH FINDERS.....	10
HECTA.....	10
DEPTH TRANSDUCERS	11
MASTHEAD UNITS.....	12
A-TYPE MASTHEAD UNIT	12
C-TYPE MASTHEAD UNIT	12
MINI MASTHEAD UNIT	12
283 MASTHEAD UNIT.....	13
213 MASTHEAD UNIT.....	14
213 VERTICAL MASTHEAD UNIT.....	15
496 MASTHEAD UNIT.....	16
TYPE 211 WIND VANE	16
ANEMOMETERS.....	17
TYPE 150.....	17
TYPE 152 ANEMOMETER.....	17
TYPE 160 - DISCONTINUED.....	18
DIRECTION FINDERS	19
HERON/HOMER- DISCONTINUED	19
COMPASS SENSORS	20
HALCYON 3	20
SUPER HALCYON 3	21
HALCYON 2000.....	22
H1000 FLUXGATE UNIT.....	22
HALCYON GYRO STABILISED COMPASS SENSOR.....	23
RUDDER AND MAST ROTATION SENSORS.....	24
ROTARY RUDDER POSITION SENSOR.....	24
LINEAR FEEDBACK SENSOR	24
TANK CONTENTS/LEVEL SENSING SYSTEM.....	25
LOADCELL SENSORS	26
METEOROLOGICAL SENSORS.....	27
SEA TEMPERATURE SENSOR.....	27
AIR TEMPERATURE SENSOR	27
BAROMETRIC PRESSURE SENSOR	28

BOAT SPEED SENSORS

Impeller Type



Impeller Type Speed Sensor. Part No. **117-00-120**

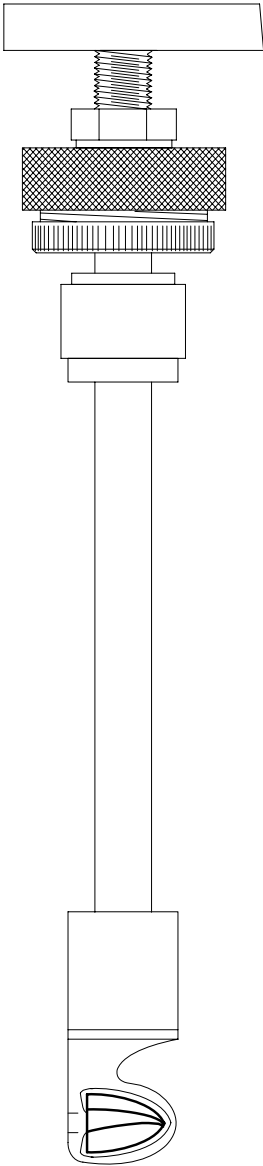

Impeller Type Speed Sensor for use with a Shut-Off-Valve (Part No. **117-00-124**)

Unit Description	Hull Housing Material/Type	Sensor Body Diameter	Sensor Body Length	Cable Termination	Part Number	Impeller Spares Kit
Speed Sensor, Impeller Type	White Plastic	31mm	88mm (excluding top fittings)	Bare Wires	117-00-120	110-10-B21
Speed Sensor, Impeller Type	Bronze	31mm	88mm (excluding top fittings)	Bare Wires	117-00-060	110-10-B21
Speed Sensor, Impeller Type for Shut-Off valve Housings	Shut-Off Valve	31mm	251mm	Bare Wires	117-00-124	110-10-B21
Impeller Spares Kit (Black)	All	n/a	n/a	n/a	110-10-B21	n/a

Note: items marked in **Red** are discontinued product lines. Please contact B&G Service for a solution.

Paddlewheel Type

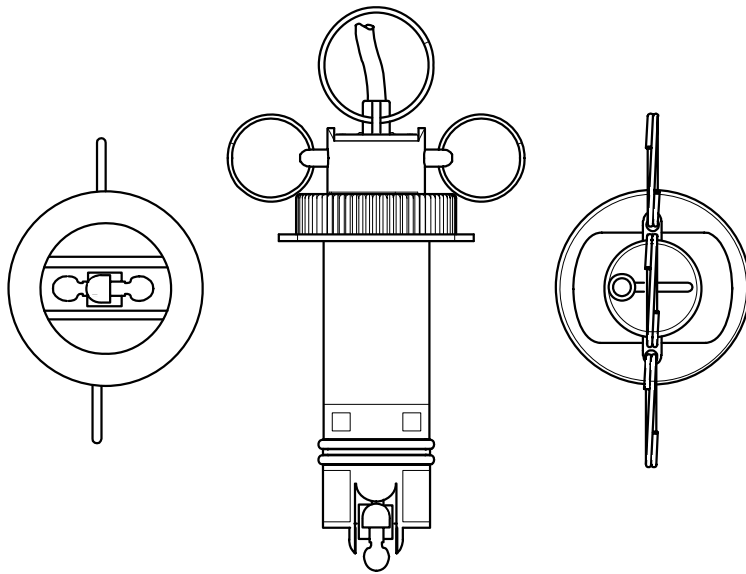

Modern Four Blade Paddlewheel Speed Sensor
(Part No. SEN-SPEED-N, H, or P)

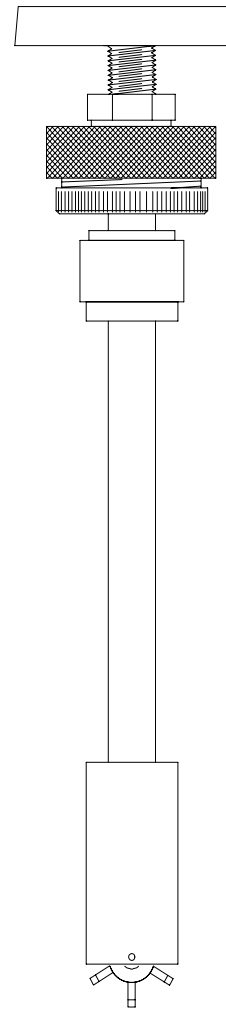

Six Blade Paddlewheel Sensor for use with a
Shut-Off-Valve (Part No. 202-00-064)

Unit Description	Sensor Part Number	Hull Housing Material/Type	Sensor Body Diameter	Sensor Length	Cable Termination	Paddlewheel Spares Kit
Network Paddlewheel, Low-speed (6 blades) old type	610-0A-026	White Plastic	31mm	105mm	Network Plug	202-00-129
Hydra/Focus Paddlewheel, low-speed (6-blades), old type	202-00-100	White Plastic	31mm	105mm	Bare wires	202-00-129
Network Paddlewheel, low-speed (6-blades), old type	610-0A-036	Bronze	31mm	105mm	Network Plug	202-00-128
Network Paddlewheel, high speed (4-blades), old type	610-0A-129	White Plastic	31mm	105mm	Network Plug	202-00-161
Network Paddlewheel, high speed (4-blades), old type	610-0A-130	Bronze	31mm	105mm	Network Plug	202-00-160
Hydra/Focus Paddlewheel, 6-blades, blue colour	202-00-045	Black Plastic	40mm	93mm	Bare Wires	202-00-054
Hornet 4 Paddlewheel, 6-blades red colour	202-00-036	Black Plastic or Bronze	40mm	93mm	Bare Wires	202-00-054
Shut-Off Valve Paddlewheel Sensor	202-00-064	Bronze Shut-Off Valve	31mm	232mm	Bare Wires	202-00-129
Network Paddlewheel, 4-blades	SEN-SPEED-N	Bronze or Black Plastic	31mm (insert only)	90mm	Network Plug	SEN-SPRS-SPD
Hydra Paddlewheel, 4-blades	SEN-SPEED-H	Bronze or Black Plastic	31mm (insert only)	90mm	Bare Wires	SEN-SPRS-SPD
h1000 Speed Sensor, 4-blade, 3m cable	SEN-SPEED-P	Bronze or Black Plastic	31mm (insert only)	90mm	Bare Wires	SEN-SPRS-SPD

Notes:

- Items marked in **Red** are discontinued product lines. Please contact B&G Service for a solution.
- The 202-00-045 can be replaced with SEN-SPD-HP (includes sensor, flapper insert and hull-housing)



Network Six-Blade, Low-Speed Paddlewheel Sensor (Part No. 610-0A-026)



Network Four-Blade, High-Speed Paddlewheel Speed Sensor (Part No. 610-0A-129)



Six-Blade Paddlewheel Speed Sensor – Hornet 4 System (Part No. 202-00-036)



Four-Blade Paddlewheel Sensor used on (Part No. SEN-SPEED-N, H, or P)

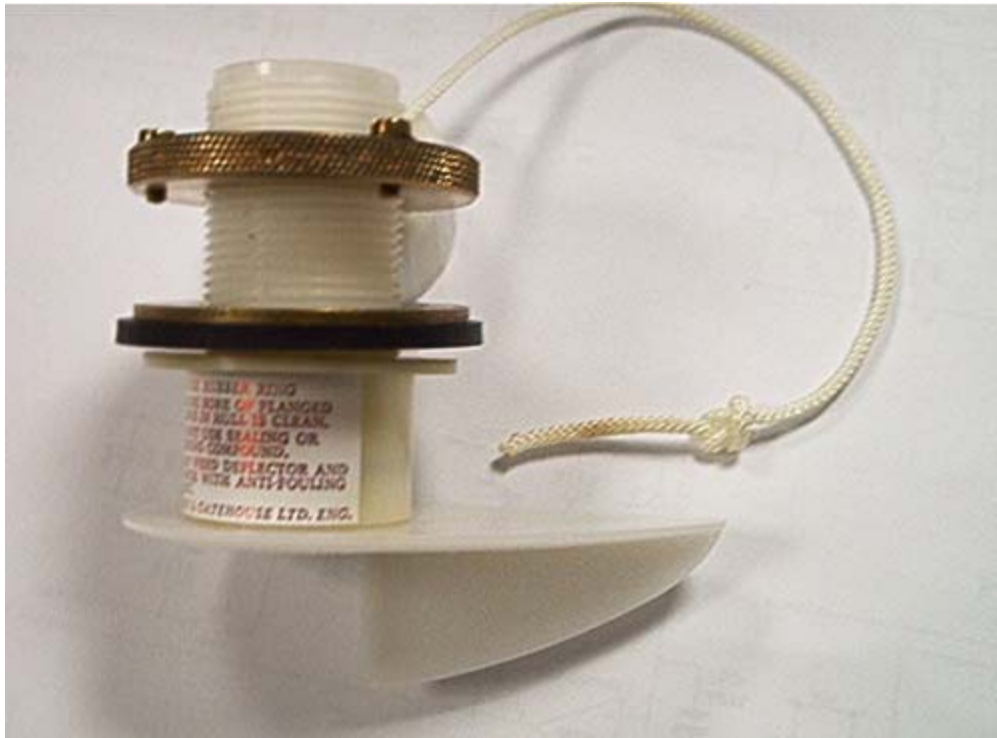







Housing for an Impeller-Type Speed Sensor (Part No. 117-00-046)



The shut-off-valve is used mainly on larger vessels; the insulation packing prevents corrosion caused by electrolytic action on steel hulled boats. (Part No. Housing – 155-00-025, Insulation Kit -155-30-017).

Paddlewheel Spares Kits

 <p>202-00-128 Low Speed, Bronze Housing, pre-1996 B&G</p>	 <p>202-00-129 Low Speed, Plastic Housing, pre-1996 B&G</p>
 <p>202-00-160 High Speed, Bronze Housing, pre-1996 B&G</p>	 <p>202-00-161 High Speed, Plastic Housing, pre-1996 B&G</p>
 <p>202-00-54 Pre-1996 Airmar Sensors</p>	 <p>SEN-SPRS-SPD Post-1996 Airmar Sensors</p>

Sonic Speed

Description: Matched pair of sensors connected to a central processor
 Date introduced: 1986
 Date Discontinued: Current system
 Part Number: 184-00-081

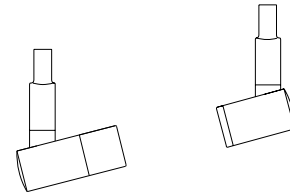
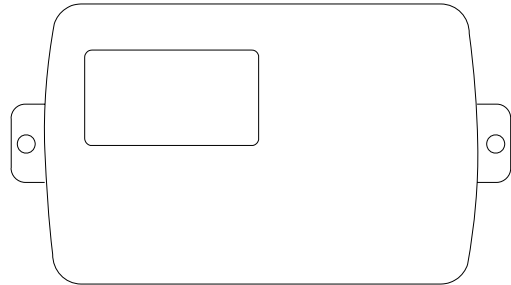

The Sonic Speed Sensor System uses two sensors, positioned fore and aft and the boat's speed is calculated by measuring the time taken for a series of sonic pulses to travel through the water between the two sensors.

XTL- Microsonic Speed Sensor

Description: Sonic speed sensors mounted in an underwater fin assembly
 Date Introduced: 1988
 Date Discontinued: Current system
 Part Number: 275-00-001/017, 275-00-032/032, 275-00-039, 275-00-045/046
 dependent on stud length and material type

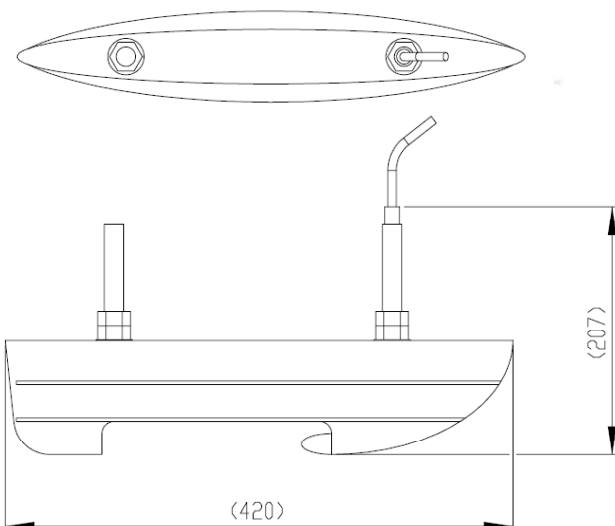

Ultrasonic Speed

Description: Used with Hydra and Hercules systems. Boat speed measurement obtained by transmitting ultrasonic pulses into the water, and obtaining echoes from particles suspended in the water.

Date introduced: 2001

Date Discontinued: 2006

Part Number: BGH071002 Transducer
BGH071003 Junction Box



BGH071002 Transducer



BGH071003 Junction Box

DEPTH FINDERS

Hecta

Description: Transistorised echo sounder
Date Introduced: 1958
Date Discontinued: 1978 – Superseded in 1979 by the 200 meter range Hecta echo sounder



DEPTH TRANSDUCERS

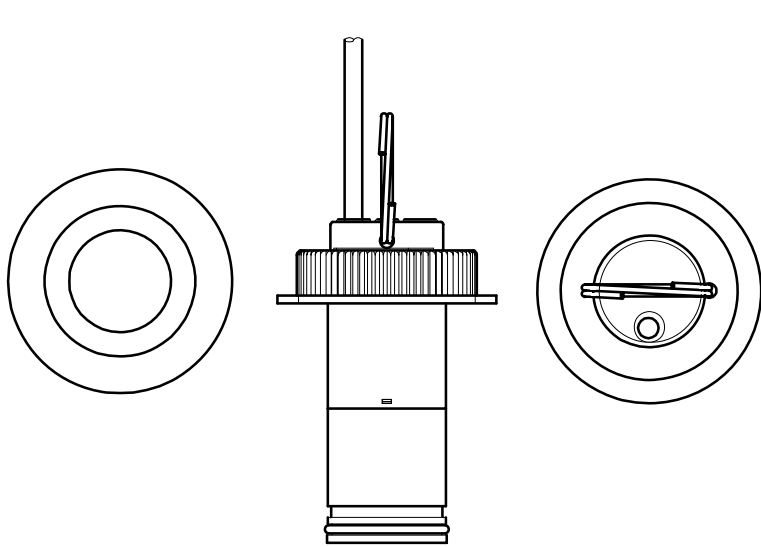

Modern Depth Sensor
(Part No. SEN-DEPTH-H)

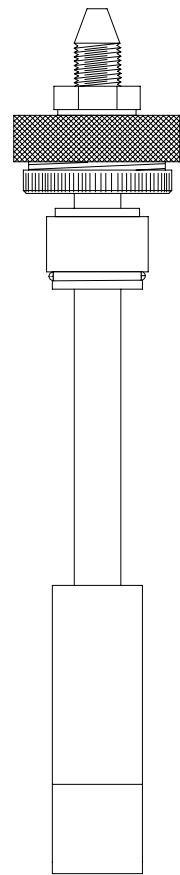

Depth Sensor for use with a Shut-Off-Valve
(Part No. 157-AA-038)

Unit Description	Part Number	Hull Housing Material/Type	Sensor Body Diameter	Sensor Length	Cable Termination	Technical
Hydra/Focus Depth Transducer	401-00-011	White Plastic	31mm	109mm	Bare Wires	Passive Coil
Network Depth Transducer	610-0A-027	White Plastic	31mm	109mm	Network Plug	Passive Coil
Hydra Transducer, shaved face	401-00-027^[1] (use 199-00-018)	Bronze Housing	31mm	109mm	Bare Wires	Passive Coil
Hydra/Focus Depth Transducer	199-00-018	Bronze Housing	31mm	109mm	Bare Wires	Passive Coil
Network Depth Transducer	610-0A-040	Bronze Housing	31mm	109mm	Network Plug	Passive Coil
Hecta/Hydra/Network Long Reach Depth Transducer	199-00-029	Bronze	31mm	158mm	Bare Wires	Passive Coil
Hecta Mk 6	111-00-049	Bronze	31mm	109mm	Co-ax Connector	Passive Coil
Network Depth Transducer	SEN-DEPTH-N	Black Plastic	41mm	89mm	Conexall Connector	Passive Coil
Hydra Depth Transducer	SEN-DEPTH-H	Black Plastic	41mm	89mm	Bare Wires	Passive Coil
h1000 Sail Passive Transducer 170kHz	SEN-DEPTH-P	Black Plastic or Bronze	41mm	89mm	Bare Wires	Ceramic only ^[2] Use with SDIE
h1000 Power Active Transducer 235kHz	SEN-DEPTH-A2	Black Plastic or Bronze	41mm	89mm	Bare Wires	NMEA

^[1] Items marked in **Red** are discontinued product lines. Please contact B&G Service for a solution.

^[2] 3m cable forms part of a tuned circuit. Do not cut cable to length.

MASTHEAD UNITS

A-Type Masthead Unit

Description: Used with very old Hornet systems
 Date Introduced: 1950's
 Date Discontinued: 1972
 Part Number: **(discontinued)** Please contact B&G Service for a solution.

C-Type Masthead Unit

Description: Used with Horsa, Hornet and Hercules 190/290 systems
 Date Introduced: 1972/73
 Date Discontinued: 1986/87
 Part Number: 137-00-035 **(discontinued)** Please contact B&G Service for a solution.

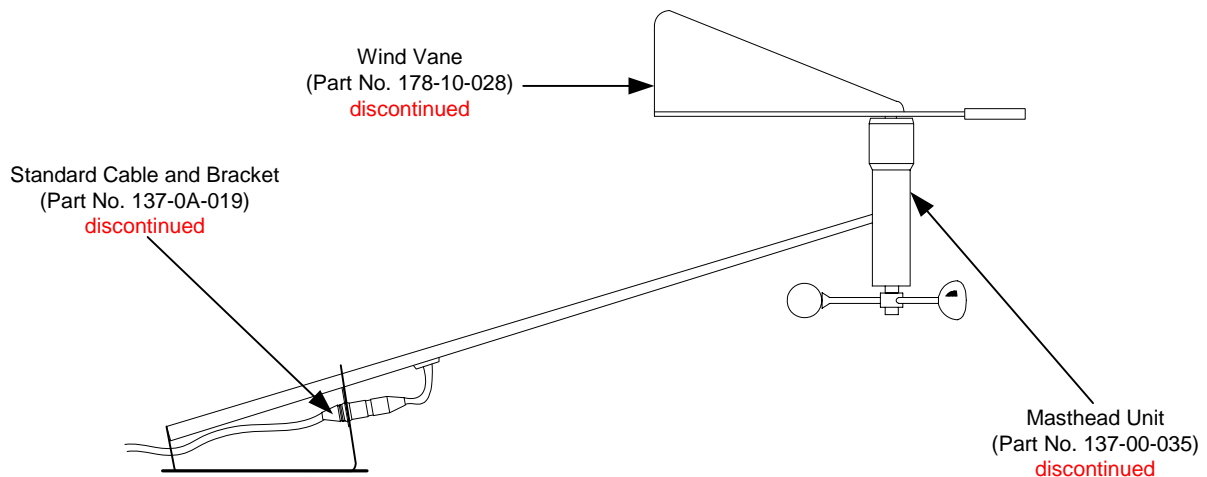

Mini Masthead Unit

Description: Used with Hercules 190/290 systems
 Date Introduced: 1984
 Date Discontinued: 1985
 Part Number: **(discontinued)** Please contact B&G Service for a solution.

283 Masthead Unit

Description: Used with Focus and early Network systems
Date Introduced: 1988
Date Discontinued: 1996
Part Number: 283-00-001 (discontinued) Please contact B&G Service for a solution.

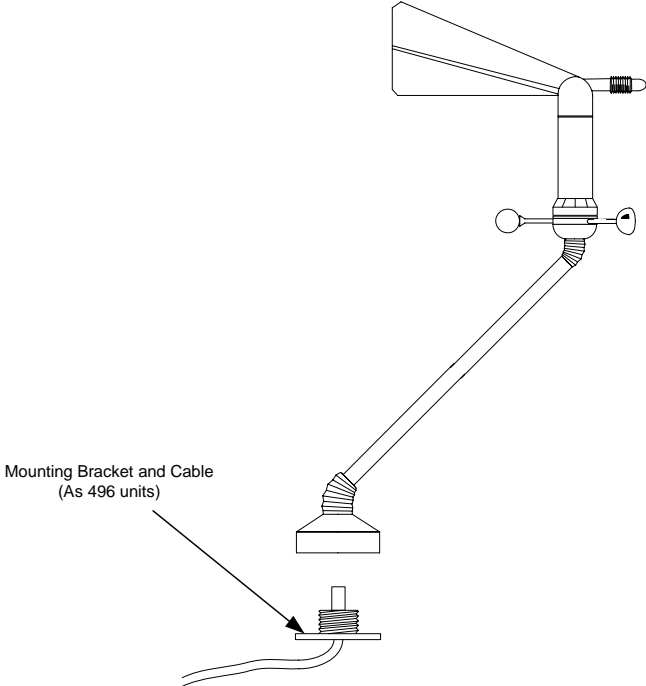

213 Masthead Unit

Description: Used with Hercules 390, Hydra and Hercules systems
Date introduced: 1985/86
Date Discontinued: Current Unit
Part Number: 213-00-002

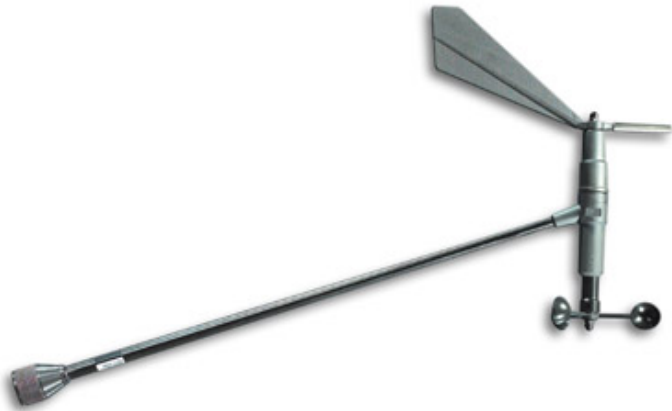

Note. Skirt Assy. and Masthead support including nuts are available as a pack. (Part No. MHU-MLDGS)

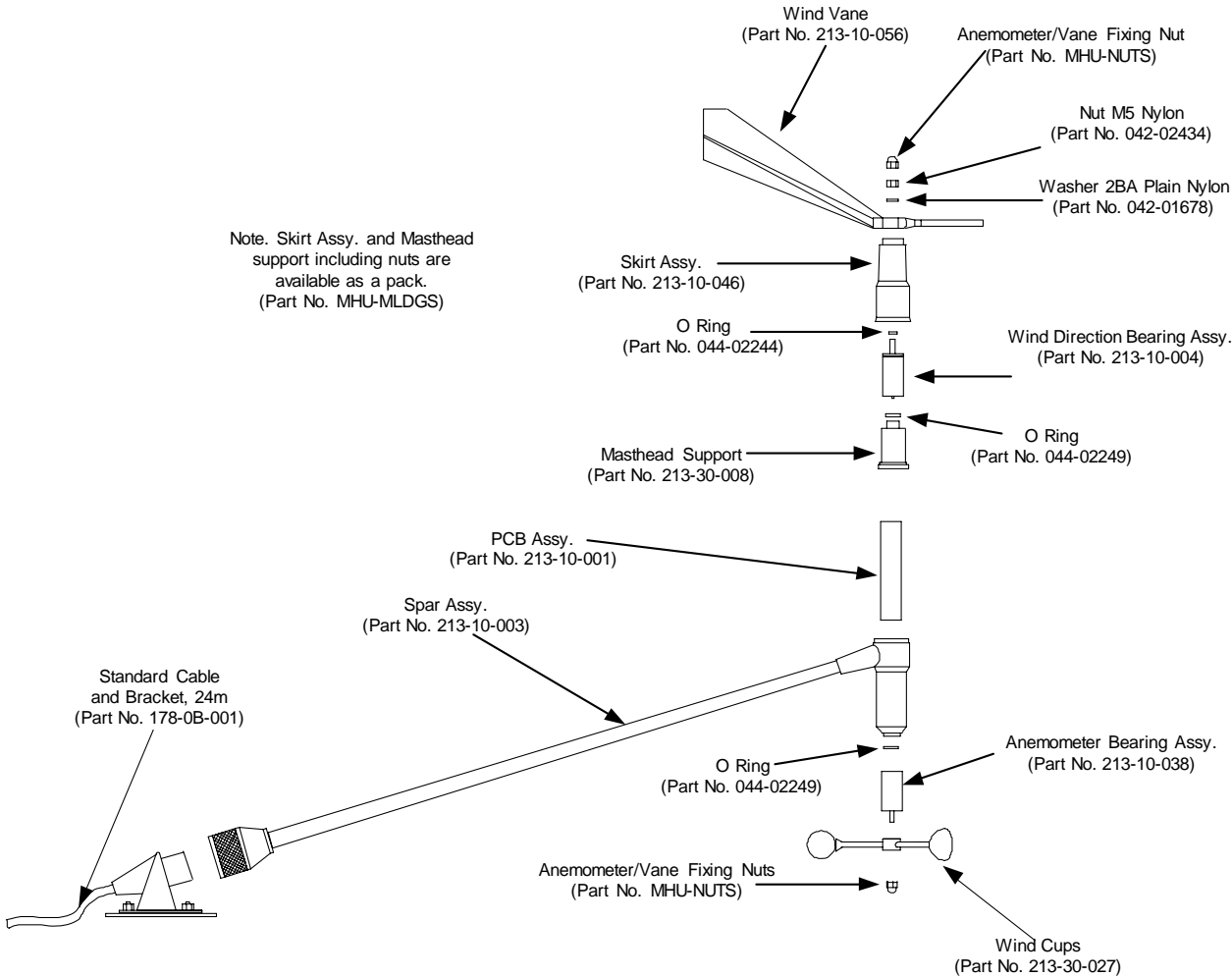

213 Vertical Masthead Unit

Description: Used with Hydra and Hercules systems
 Date Introduced: 1999
 Date Discontinued: Current Unit
 Part Number: BGH031001 (32"), BGH031002 (42"), BGH031002S (Ocean Spec.*),
 BGH031003 (57") & BGH031003S (Ocean Spec.*)
 *Ocean Spec constructed with extra laminate for increased durability

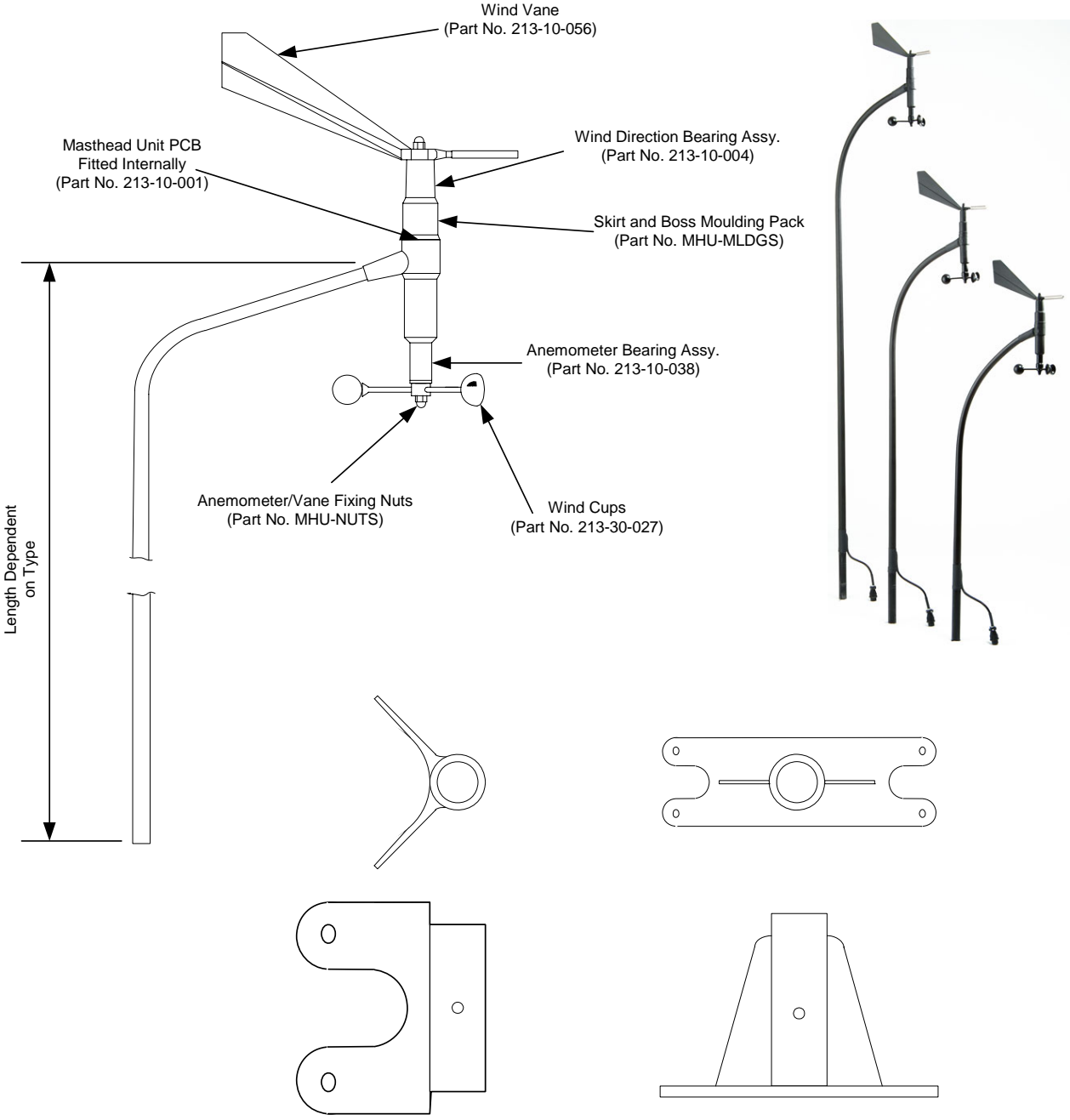

213 Vertical Masthead Unit
 Face Mounting Bracket
 (Part No. BGH030009)

213 Vertical Masthead Unit
 Top Mounting Bracket
 (Part No. BGH030008)

496 Masthead Unit

Description: Used with Network and h1000 systems
 Date Introduced: 1996
 Date Discontinued: Current Unit
 Part Number: 496-00-001

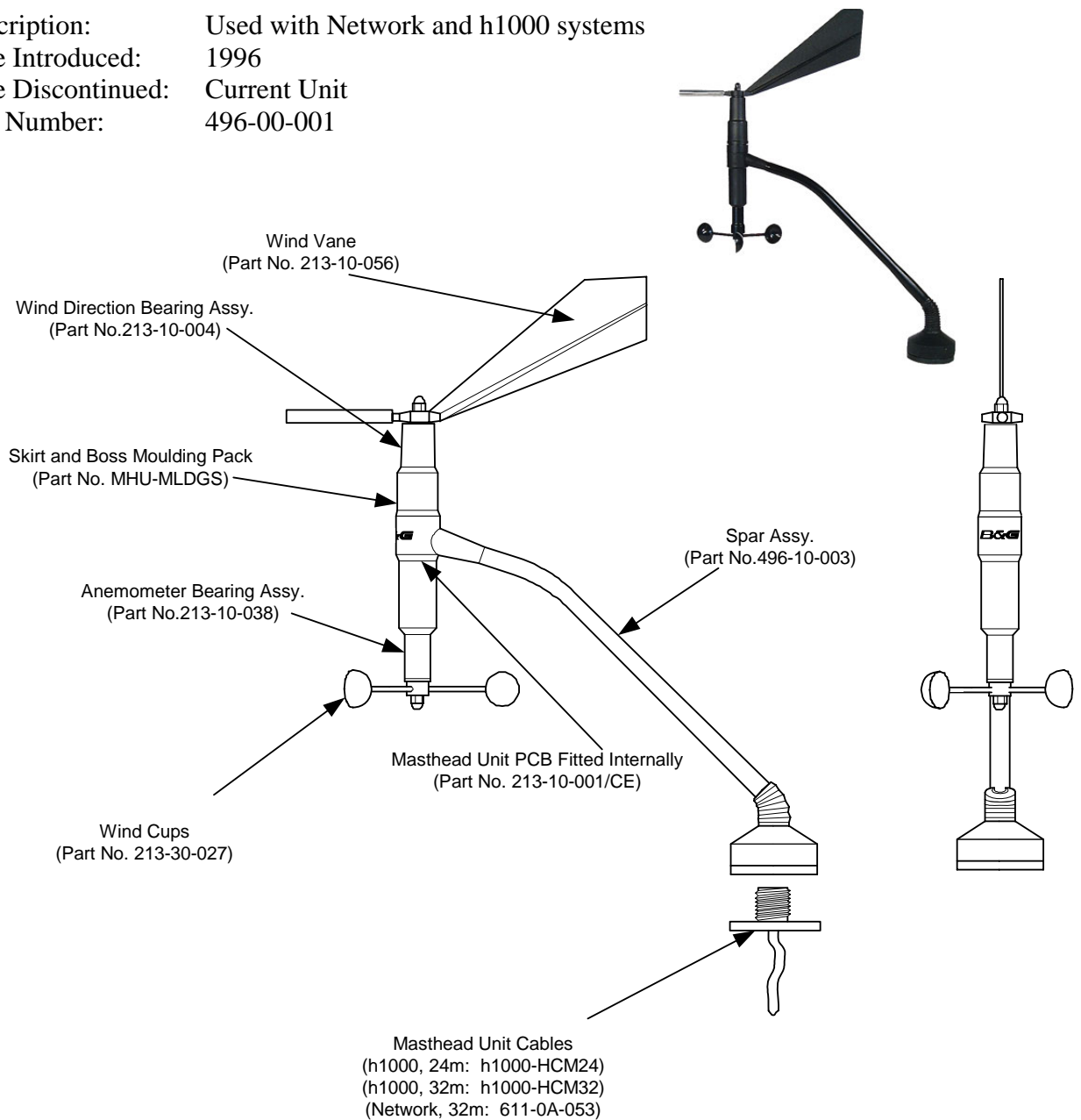

Type 211 Wind Vane

Description: Primarily used with early B&G industrial systems in conjunction with the 152 Anemometer
 Date Introduced: 1976
 Date Discontinued: 1985 (discontinued) Please contact B&G Service for a solution.

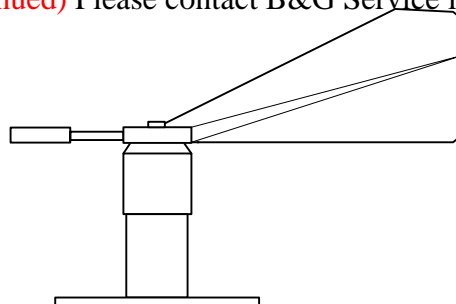

ANEMOMETERS

Type 150

Rotation of the Fan blades provides the power to operate the readout display, directional. Specialist use, for measuring wind speed in wind tunnels etc. **(Discontinued)**

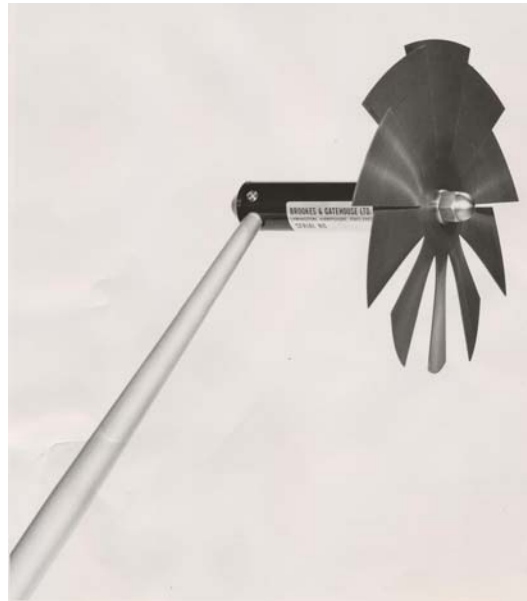

Fan Type Anemometer

Type 152 Anemometer

Primarily used to provide accurate wind speed information, for early B&G Industrial Systems. This unit, in conjunction with the Model 211 Wind Vane, was also used to provide wind information for early B&G marine systems. **(Discontinued)** Please contact B&G Service for a solution.

ANEMOMETER: MODEL 152

FOR MARINE OR LAND USE

- HIGH RELIABILITY
- ACCURACY
- ROBUST DESIGN
- LOW INSTALLATION COST
- LOW MAINTENANCE COST

Type 160 - discontinued

WIND SPEED AND DIRECTION INDICATOR MODEL 160

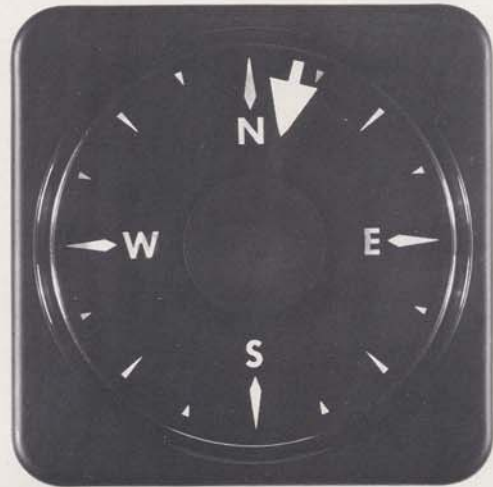

The Model H wind speed and direction indicator is designed and manufactured to the highest standards to meet a wide variety of commercial and industrial applications. It is sealed against moisture and dust and is intended for use at air fields, power stations, hovercraft landing pads, oil rigs, on offshore data collecting buoys and as the controlling sensor for pollution monitoring. It is suitable for any application where accurate wind speed and direction is required. The system comprises a detachable masthead unit, a control unit and the two indicators. All the units are sealed against the ingress of moisture and dust and are corrosion and vibration proof. Reliable operation is obtained at very low wind speeds. The instrument is designed to give a meter read-out or operate pen recorders.

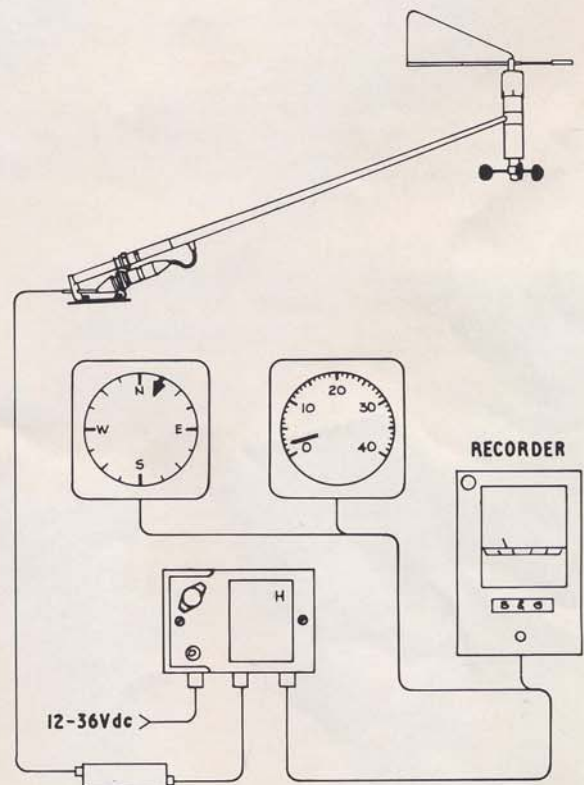

DIRECTION FINDERS

Heron/Homer- discontinued

Description: Long wave direction finding aerial
Date Introduced: 1955
Date Discontinued: 1963



COMPASS SENSORS

Fluxgate Type

Halcyon 3

Description: Used with Hercules 190 systems
Date Introduced: 1981
Date Discontinued: 1987
Part Number: (discontinued)



Sensor viewed from the base showing the connector



Sensor viewed from the top showing mounting orientation

Super Halcyon 3

Description: Used with Hydra/Hercules 190, 290 and 390 systems
Date Introduced: 1987
Date Discontinued: 1997
Part Number: 386-00-009 (discontinued) Please contact B&G Service for a solution.



Sensor viewed from the base showing the connector



Sensor viewed from the top showing mounting orientation
(Later models were white in colour)

Halcyon 2000

Description: Used with Hydra/Hercules systems
Date Introduced: 1997
Date Discontinued: Current unit
Part Number: 486-00-009



View of the sensor showing the Fastnet connector

H1000 Fluxgate Unit

Description: Used with h1000 systems
Date Introduced: 2001
Date Discontinued: Current unit
Part Number: h1000-CSU



View of sensor showing the two FastNet² Databus connections at the base

Halcyon Gyro Stabilised Compass Sensor

Description: Used with the Halcyon Gyro Processor on Hydra/Hercules systems and ACP Mk2 from 2003

Date Introduced: 1999

Date Discontinued: Current unit

Part Number: BGH060002



RUDDER AND MAST ROTATION SENSORS

Rotary Rudder Position Sensor

Description: Used with the Helmstar, Hydra, Hercules, Network and h1000 autopilot systems

Date Introduced: 1985

Date Discontinued: Current unit

Part Number: RRF-ACP



Linear Feedback Sensor

Description: Used with the Hydra 2000, Hercules 2000 and h1000 autopilots (Blue Type 1 and 2 Rams)

Date Introduced: 2003

Date Discontinued: Current unit

Part Number: SEN-RUD-LFB



TANK CONTENTS/LEVEL SENSING SYSTEM

Description: Used with the Hydra/Hercules Main Processor
Date Introduced: 2002
Date Discontinued: 2005
Part Number: BGH090001 (aluminium), BGH090002 (brass) or BGH090003 (stainless steel) - **discontinued**

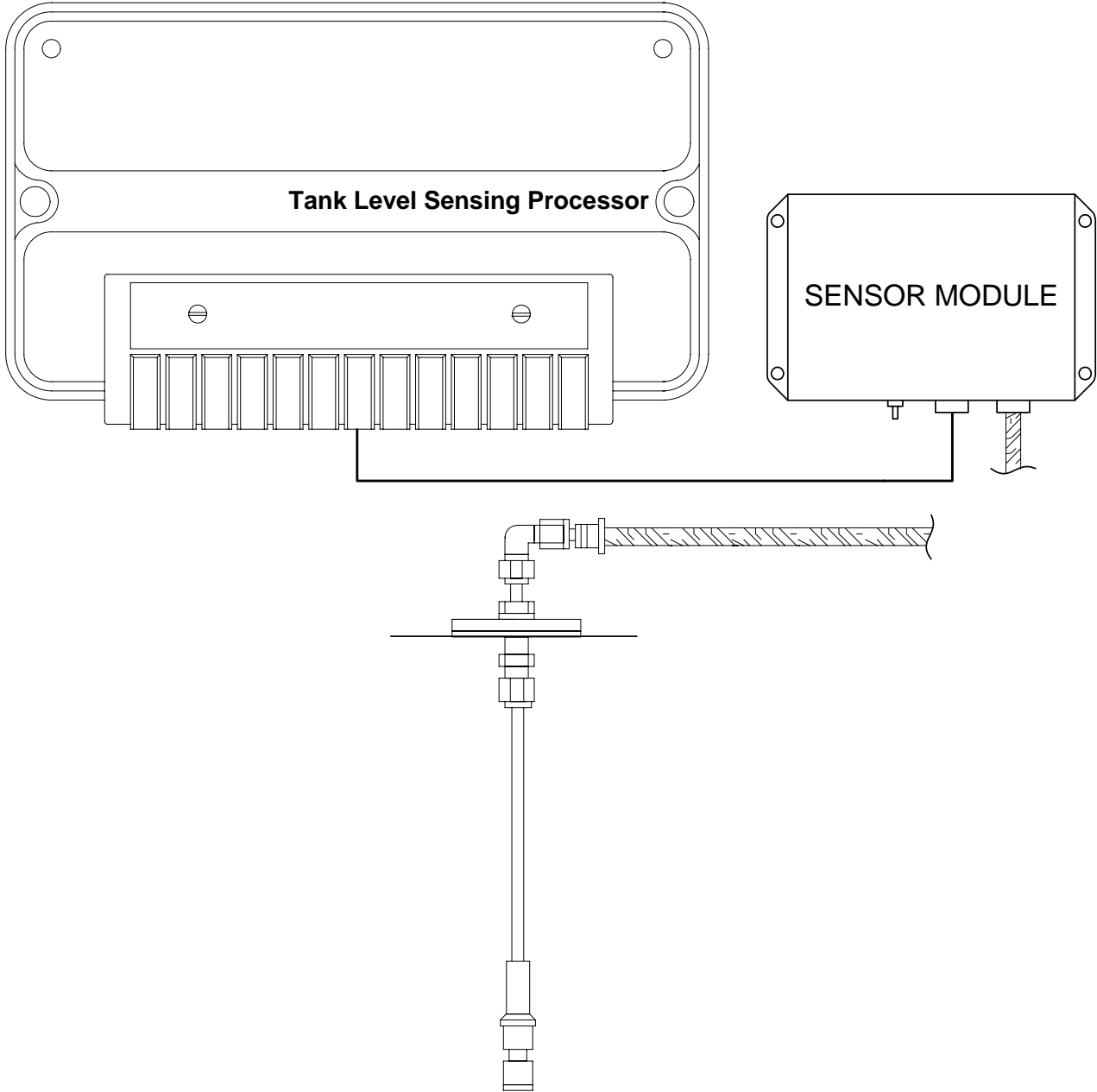

Additional Sensor Modules and fittings Part No. **BGH091001 (aluminium)**, **BGH091002 (brass)** or **BGH091003 (stainless steel)**

LOADCELL SENSORS

Description: Used with the Hydra 2000 and Hercules 2000 systems
Date Introduced: 2000
Date Discontinued: Current unit
Part Number: Standard Loadcell Part Nos.

- BGH041001 - 12.7mm (1/2")
- BGH041001 - 16mm (5/8")
- BGH041003 - 19mm (3/4")
- BGH041004 - 23mm (7/8")
- BGH041005 - 25.4mm (1")
- BGH041006 - 28.5mm (1 1/8")
- BGH041007 - 32mm (1 1/4")

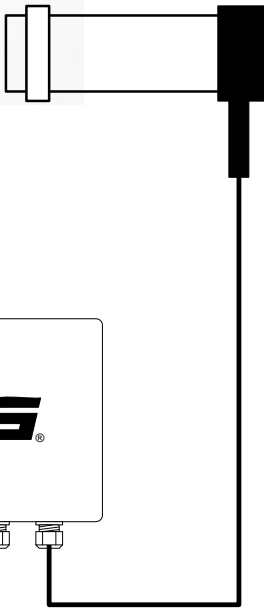

Amplifier
Analogue or Digital
* Analogue Amplifier
discontinued

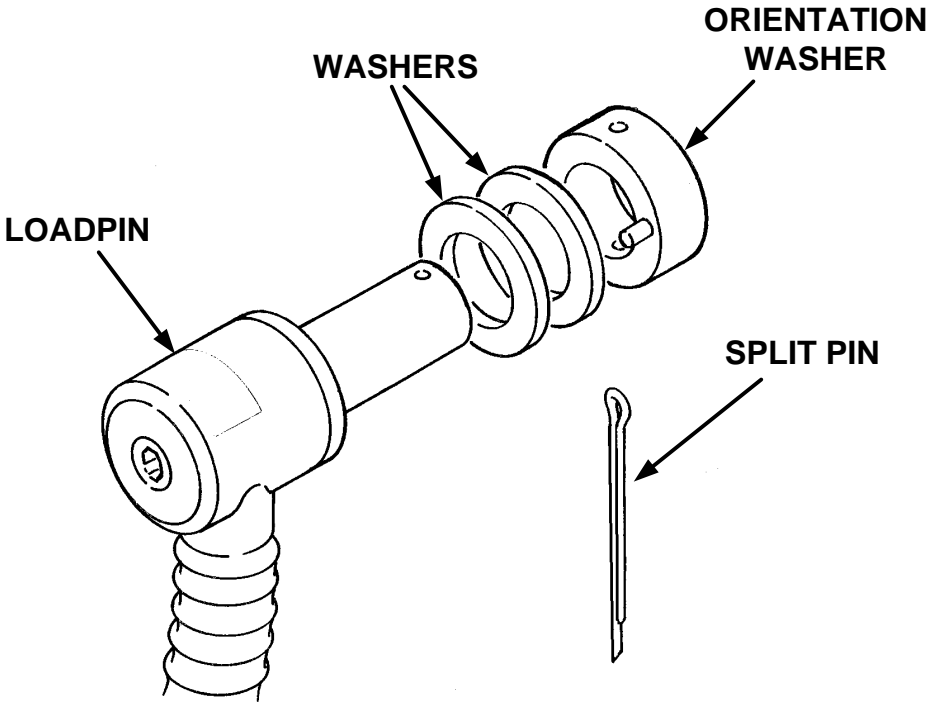

METEOROLOGICAL SENSORS

Sea Temperature Sensor

Description: Used with Hydra and Hercules Systems
Date Introduced: 1988
Date Discontinued: Current unit
Part Number: 224-00-065



Air Temperature Sensor

Description: Used with Hydra and Hercules Systems
Date Introduced: 1988
Date Discontinued: Current unit
Part Number: 224-00-066



Barometric Pressure Sensor

Description: Used with Hydra and Hercules Systems
Date Introduced: 1988
Date Discontinued: Current unit
Part Number: 690-00-007

